

The Feral Cello: A Philosophically Informed Approach to an Actuated Instrument

Tom Davis
Bournemouth University
Poole House,
Talbot Campus, BH12 5BB
tdavis@bournemouth.ac.uk

ABSTRACT

There have been many NIME papers over the years on augmented or actuated instruments [2][10][19][22]. Many of these papers have focused on the technical description of how these instruments have been produced, or as in the case of Machover's 'Hyperinstruments' [19], on producing instruments over which performers have 'absolute control' and emphasise 'learnability, perfectibility and repeatability' [19]. In contrast to this approach, this paper outlines a philosophical position concerning the relationship between instruments and performers in improvisational contexts that recognises the agency of the instrument within the performance process. It builds on a post-phenomenological understanding of the human/instrument relationship in which the human and the instrument are understood as co-defining entities without fixed boundaries; an approach that actively challenges notions of instrumental mastery and 'absolute control'. This paper then takes a practice-based approach to outline how such philosophical concerns have fed into the design of an augmented actuated cello system, *The Feral Cello*, that has been designed to explicitly explore these concerns through practice.

Author Keywords

Post-Phenomenology, Agency, Actuated, Cello, Post-human

ACM Classification

- Applied computing~Performing arts
- Applied computing~Sound and music computing
- Hardware~Sensors and actuators

1. INTRODUCTION

As a practice-based researcher my improvisational practice involves the use of technologies for the creation of performance environments within which I partake in technologically mediated-performance. I am particularly interested in the relationship with technology in this setting and the ways in which we can understand and problematise the performer-technology relationship. I position myself as part of the growing body of instrument-builder/ improvisers (such as [3][9][12][26]) that are exploring techno-centric approaches to musical improvisation that implicitly examine these human-technology relationships through their creative practice. My practice is informed by my understanding of a prominent discourse within the field of the Philosophy of Technology that addresses the conceptualisation of humans' relationship with technology. In particular, there has been a growing acceptance

of a rejection of technological determinism. This rejection has led theorists to explore human-technology interactions from a variety of social, political and philosophical perspectives. Attempts to characterise interactions and relationships between technologies and humans have been made by academics such as Ihde [16] Feenberg [8], Haraway [14], Hayles [15], and Verbeek [27] to different extents. There has also been discussion of various levels of integration between technologies, the body and the mind as exemplified by recent developments in philosophies of mind and the cognitive sciences. Some of these propose not only an embodied, situated theory of mind but also an extended theory of mind in which technologies can be conceived as part of an extended cognitive system [3][4]. Finally, there has been growing discussion regarding the agency of technology in the processes of creation/interaction, and in the co-evolution of human-machine interactions. Post-phenomenological and post-human understandings of our relationships with technology in particular, have been put forward as an interesting avenue to conceptualise and explore the inter-agency or intra-agency of humans and technology within a performance context [3]. This paper outlines these philosophical concepts in as much as they have fed into the design of a recent creative output *The Feral Cello* produced in collaboration with cellist Laura Reid [24]. Following Green [13] I feel that a practice-led approach where the first concerns are of a musical nature can highlight how the technological and philosophical concerns have affected the instrumental design and musical activity.

2. PHILOSOPHICAL CONTEXT

Implicit and in some cases explicit, in the body of techno-centric improvisational context outlined in the introduction is a rejection of the notion of technological determinism [8]. Technological determinism, still arguably the tacitly accepted view of technology by society, suggests that 'technology operates in a decontextualized autonomous domain' [7], such that technology is held to follow a fixed path of progression, which is pre-determined and unavoidable, and over which humans have no influence [8]. Di Scipio [7] states that a deterministic conception of technology suggests that technology operates at 'an autonomous extra social level' that implies for the artist that the technical environment within which they work 'is not her/his affair at all' [7]. Feenberg [8] describes an alternative to technological determinism that he terms 'Critical Theory'. This situates technology, not as a neutral tool, but rather as something that shapes and is shaped by societal functions and use. In this conception the progression of technology is also open to being influenced and changed by users who in turn are also shaped through its use. Taking such a non-deterministic stance suggests that for a musician, dealing with the technology as part of their performance practice is 'an opportunity to challenge



Licensed under a Creative Commons Attribution 4.0 International License (CC BY 4.0). Copyright remains with the author(s).

NIME'17, May 15-19, 2017, Aalborg University Copenhagen, Denmark.

established and uncritically accepted practices and theories, the known modalities of personal or shared modalities of music making' [7].

3. INSTRUMENTAL AGENCY

3.1 Agency in Practice

As part of an active decision to explore such issues as part of my performance practice I have become increasingly interested in ways of foregrounding & problematising the notion of technological agency as part of the creative process. As I see my work as part of the critical context of instrument builders/improvisers I would first like to explore some other projects that have explicitly informed my creative approach.

James Ferguson in *Imagined agency: Technology, Unpredictability and Ambiguity* [9] discusses his practice as a performer of technologically mediated music. In this article Ferguson is in particular writing about a hybrid electric guitar setup called Machine-Assembled Dislocation (MAD). Ferguson categorises the human/machine interaction as performing with 'feral technologies' [9, p.143], in which the music is 'an emergent form, radiating from pre-composed situations and instrumental ecologies, the performance of and in which it is improvised' [9, p.145]. For Ferguson, the instrumental agencies are imagined, yet they are no less important as they provide 'fruitful creative stimulus' [9, pg 143] to the performers and help articulate his practice in which he 'seeks out resistance and agency in a variety of forms, and attempts to interact with it' [9, p.143].

David Borgo's work and writing has been a large inspiration to this project. Borgo proposes that he devises hybrid instruments that both 'extend and complicate our sense of control' [3, p.2]. He has strived to avoid divisions between artists and technologists specifically looking to avoid the 'division ... between acoustic and electronic performers'. Borgo presents perhaps the most radical conception of agency in practice drawing on Actor Network Theory [17] to provide 'insight concerning "distributed agency" or "interagency" between humans and technology' as a way on conceptualising his interactions with technology in his musical improvisations.

Such discussions provide a conception of instrumental agency on a continuum from the purely imagined agency of Ferguson, where the agency is ascribed by the performer, to a more post-phenomenological understanding of agency in which the agency of the humans and technology are mutually co-productive of each other.

3.2 Agency in Theory

This continuum of degrees of agency is also represented in the literature. An imagined agency can be likened to Dennett's Intentional Stance. In *Intentional System Theory* Dennett sets out an intentional stance one can take to technology in adopting a stance where we can interpret, explain or predict the behavior of something by attributing minds to them [6, p.1]. 'The intentional stance is the strategy of interpreting the behavior of an entity (person, animal, artifact, whatever) by treating it as if it were a rational agent who governed its 'choice' of 'action' by a 'consideration' of its 'beliefs' and 'desires' [6, p.1]. For Dennett the intentional stance is the natural way of trying to understand something if it too complicated to break it down into an understanding of its internal logics, leading to humans to anthropomorphise common encounters with technologies such as their cars. This I see as very similar to Ferguson's conceptualisation of his performance system.

Idhe [16] takes a different approach in examining technologies in use. In particular, in how they might mediate our interaction with the world. Building on a phenomenological understanding of intentionality, the property of mental phenomenon as being directed onto an object Idhe presents four different ways in which technology can mediate this intentionality. The four categories are: Embodied; the technology becomes part of the body schema: Hermeneutic; they become representations of reality with which we react: Alterity; 'technology-as-other' [16, p.98] the technology becomes something with which we interact: Background; technologies create a context for our perceptions. Idhe describes a relationship with a musical instrument as an embodied relation, one in which 'The player picks up the instrument (having learned to embody it) and expressively produces the desired music' [16, p.95]. However, for computer based music, particularly where the computer is involved in 'random' decision making, he likens the interactions to those described by the alterity relation. In this relation, the technology ceases to be a transparent tool but rather becomes something that is present to our consciousness. Technology in this instance possess agency through the fact that it modifies or mediates human intentionality.

Pickering [23] takes this post-phenomenological understanding further. For Pickering, human and material agency are both 'temporally emergent', such that they simply emerge 'in the real time of practice' [23, p.566]. He states that his analysis of scientific practice 'is posthumanist not simply in its twinning of human with material agency but, more profoundly, in its insistence that material and human agencies are mutually and emergently productive of one another' [23, p.566]. Pickering is thus not just recognizing that material entities and humans can possess agency or that technologies can exhibit agency through their use but rather that human and technology agency are mutually co-defining and co-constructive.

Barad does not attribute agency to human intentionality or subjectivity, she does not believe that agency is an intrinsic attribute of an object. Rather she defines it as 'the enactment of iterative changes to particular practices through the dynamics of intra-activity' [1, p.826]. Agency is thus defined in the mode of activity, it is enacted. Barad recognises "'human', 'non human' and 'cyborgian' forms of agency" [1, p.826] Seeing the human not as a fixed form, but one whose boundaries are fluid and changeable because 'agency is a matter of changes in the apparatuses of bodily production' [1, p.826].

We have reached a place where agency is not an attribute that is possessed by an object, be that human or machine. Rather agency is something that arises in activity in the moment. It cannot be attached to fixed forms as these forms are fluid in their construction dependent on context of use and activity.

4. THE FERAL CELLO

What follows is a description of a system generated in response to this philosophical context. In an attempt to embody the idea that the musical instrument has agency as part of the creative process, the system has been designed such that the acoustics of the instrument can be altered in real time by the instrument itself.



Figure 1 Augmented Cello in use.

4.1 Technical Description

With a physical construction inspired by the growing body of actuated instruments [22] and IRCAM’s Smart Instruments [25] this system features an actuated cello whose feedback through the body of the instrument is controlled by machine listening to its own output.

An acoustic pickup under the bridge sends the cello sound to a laptop running Max [5] for processing. The Zsa.Descriptors [20] package is used to analyse the incoming sound in terms of Spectral Centroid, Spectral Flux, Spectral Brightness and Spectral Rolloff. This time dependent information is then fed into an implementation of IRCAM’s Gesture Follower [11] software. Before the performance a number of predetermined performance gestures are recorded. These gestures are such things as pizzicato on a D string, sul ponticello on an A string or open strings. As you would expect, gestures with distinctly different spectral or timing qualities work best for recognition purposes. In the performance, the algorithm attempts to match the cello sound to the recorded gestures. Once it has found a match it switches the order and type of digital signal processing applied to the sound through choosing from a set of presets predefined by the composer and inspired by Leafcutter John’s Mr Matrix [18], which is a real graphical Matrix controller for Max that allows real time swapping of DSP in performance. The DSP available is: short delay; long delay; spectral freezing; granular synthesis; distortion; enveloping; waveshaping or spectrally managed feedback. This processed audio is then played back through the body of the cello through actuators placed upon its body. This processed audio can also be separated from the cello and played back through additional loudspeakers to address issues of balance between the acoustic and electronic material. The cello the Max patch and the processed sound through the instrument can be conceived as one augmented hybrid acoustic/electronic instrument.

4.2 Compositional Concerns

The system has been developed with cellist and composer Laura Reid who has written the piece *Gemmeleg* to be performed at Noisefloor 2017 [21] and NIME 2017. *Gemmeleg* features a semi-structured improvisation in which the performer

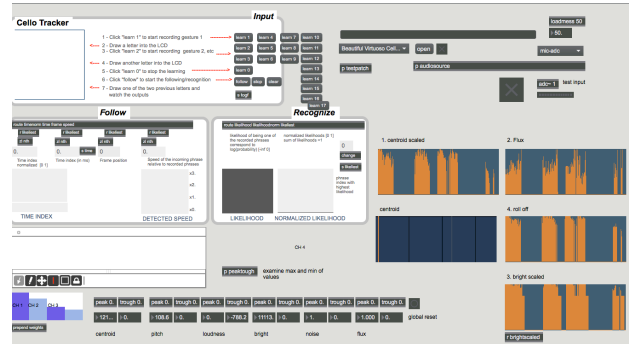

Figure 2 Screen shot of Max patch showing analysis utilizing Zsa.Descriptors and IRCAMs Gesture Follower.

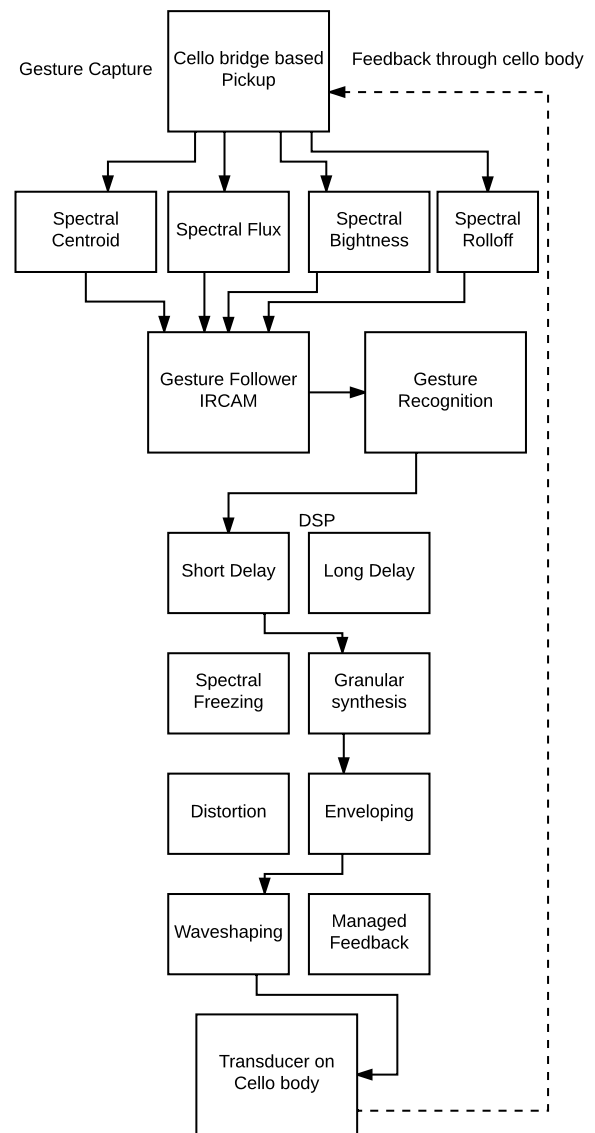

Figure 3 System outline

intends to explore five compositional ideas. Each of these five compositional ideas are linked to gestures stored in the system such that when the performer starts a new section of the improvisation it should trigger a change in the signal processing of the system. Responses from the system are consistent within each performance, i.e. the algorithm should choose the same

DSP setup depending on the recognised gesture; however, errors in the algorithmic matching process which are exacerbated by the fact that the signal processed cello sound is also feeding back through the body of the cello are actively exploited to highlight the agency of the cello as part of the improvisational process. As such, the system can switch sounds in an unpredictable way, which in turn prompts the improviser to respond. This switching not only highlights the agency of the cello within the performance but also acts as a springboard for improvisational creativity within the piece. As the DSP changes the cello's response to the performer the performer has to actively readjust their relationship to the cello both in terms of the instrument and in terms of their intention for the improvisation. I argue that this system is best understood not as a cello with separate audio processing or even as a cello with a separate performer but as a single performer/cello/machine system with mutable boundaries, both in terms of agency and subjectification.

5. CONCLUSION

This paper has presented a philosophical context for the creation of a performer-actuated cello system that seeks to explore conceptions of machinic agency through creative practice. It outlines a system that has been explicitly designed to highlight the mutable boundaries between performer, musical instrument and music within the act of performance, challenging the notion that instruments are objects to be mastered.

6. REFERENCES

- [1] Barad, K. Posthumanist Performativity: Toward and Understanding of How Matter Comes to Matter. *Signs: Journal of Women in Culture and Society* 28:3, 801-831, 2003.
- [2] Bevilacqua, F, Rasamimanana, N, Flety, E, Lemouton, S, & Baschet, F. The augmented violin project: research, composition and performance report. *Proceedings of the 2006 International Conference on New Interfaces for Musical Expression*. 2006.
- [3] Borgo, D. 2014. The Ghost in the Music, or the Perspective of an Improvising Ant. *Oxford Handbooks online*. 2014
- [4] Clark, A. *Natural-Born Cyborgs: Minds, Technologies, and the Future of Human Intelligence*. New York: Oxford University Press, 2003.
- [5] Cycling'74 Max. <http://cycling74.com> accessed 31/01/17
- [6] Dennett, D.C.. Intentional Systems Theory, in *Oxford Handbook of the Philosophy of Mind*. Mclaughlin, A, Beckerman, S, Walter (eds.), New York : Oxford University Press Starts pg 339. 2009
- [7] Di Scipio, A. Towards a critical theory of (music) technology: Computer music and subversive rationalization, *Proceeding of International Computer Music Conference 1997*.
- [8] Feenberg, A. *Critical Theory of Technology*, New York: Oxford University Press, 1991.
- [9] Ferguson, J.R. Imagined Agency: Technology, Unpredictability, and Ambiguity, *Contemporary Music Review*, 32:2-3, 135-149, 2013.
- [10] Freed, A, Wessel, D, Zbyszynski, M, & Uitti, F, M. Augmenting the Cello. *Proceedings of the 2006 International Conference on New Interfaces for Musical Expression 2006*.
- [11] Gesture Follower, http://imtr.ircam.fr/imtr/Gesture_Follower accessed 31/01/17
- [12] Green, O., *User Serviceable Parts: Practice, Technology, Sociality and Method in Live Electronic Musicking*. Ph.D Thesis, City University London 2013
- [13] Green, O. NIME Musicality and Practice-Led Methods. *Proceedings of the International Conference on New Interfaces for Musical Expression*, 2014.
- [14] Haraway, D. A cyborg manifesto: science, technology, and socialist-feminism in the late twentieth century. In D. Haraway (Ed.), *Simians, cyborgs and women: the reinvention of nature* (pp. 149–181). New York: Routledge. 1991.
- [15] Hayles, N. K. How We Became Posthuman: Virtual Bodies in *Cybernetics, Literature, and Informatics*. Chicago: University of Chicago Press, 1999.
- [16] Ihde, D. *Technology and the lifeworld*. Bloomington/Minneapolis: Indiana University Press. 1990
- [17] Latour, B. *Reassembling the Social: An Introduction to Actor-Network Theory*. New York: Oxford University Press, 2005. Kindle edition.
- [18] Leafcutter, J. Mr Matrix <http://leafcutterjohn.com/?p=1778> accessed 16/4/2017
- [19] Machover, T. and Chung, J. Hyperinstruments: Musically intelligent and interactive performance and creativity systems. In *Proceedings of the International Computer Music Conference*, 1989.
- [20] Mikhail M & Emmauel, J. Zsa.Descriptors <http://www.e-j.com> accessed 31/01/17
- [21] Noisefloor <http://www.noisefloor.org.uk> accessed 16/4/2017
- [22] Overholt, D. The Overtone Fiddle: An Actuated Acoustic Instrument. *Proceedings of the International Conference on New Interfaces for Expression*, 2011.
- [23] Pickering, A. The Mangle of Practice: Agency and Emergence in the *Sociology of Science*. *American Journal of Sociology* 99:3, 559-589, 1993.
- [24] Reid, L. www.laurareid.co.uk accessed 16/4/17
- [25] SMART instruments made in IRCAM <http://medias.ircam.fr/x2d1bf5> accessed 30/1/2017
- [26] Stapleton, P. Dialogic Instruments: Virtuosity (Re)Located in Improvised Performance "My Favorite Supplement: The Joy of the Gizmo": *LEA Special Issue*, Supplement to LMJ17 2008.
- [27] Verbeek, P. Cyborg intentionality: Rethinking the phenomenology of human-technology relations. *Phenom Cogn Sci* 7:387-395. 2008